

PRODUCT SHEET

Description:

Magnet Touch Latch Slim Grey, $\varnothing 84 \times 14 \text{ mm}$ 20 or 40mm Extension By Switch Tap, w/Square Striker With Adhesive Tape On One, Side & Screw Hole On Other Side, White RAL 9010 Plastic, Incl., Screw For Striker, Screw-On Type

Item number:

22.01.106-2

Units	Box	Carton	HS Code	Barcode
Pcs.	100	1000	3903300000	
				5704866490177

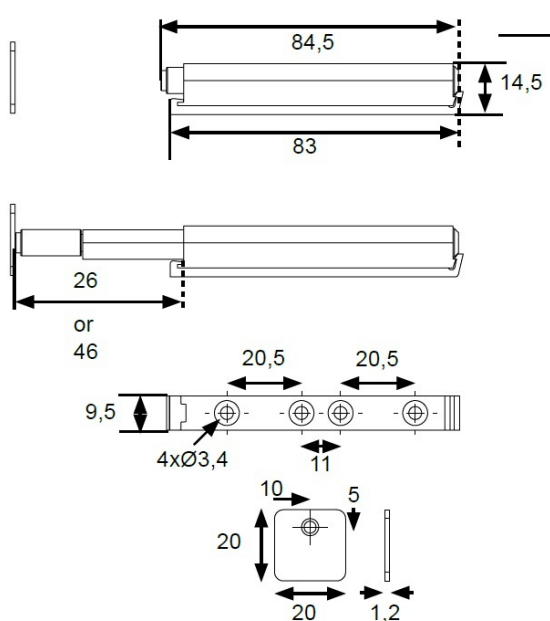

CHANGE OF EXTENSION LENGTH

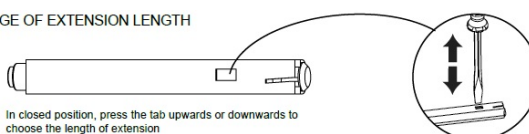

20 mm. extension

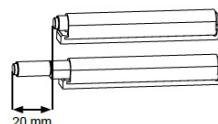

40 mm. extension

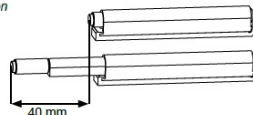

Mounting of latch

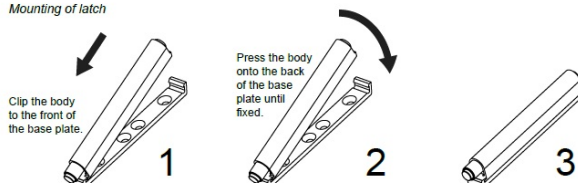

SISO A/S

Mileparken 11
DK-2740 Skovlunde
Denmark
VAT: DK 24786013

Phone +45 45 830 900

www.siso.dk
siso@siso.dk

Danske Bank
Nytorv Branch
Copenhagen
SWIFT: DABADKKK

Account no.
4180 3112 112936
IBAN Account
DK7230003112112936