



Free space 6.15

372.27.xxx



www.haefele.de/en/free-space

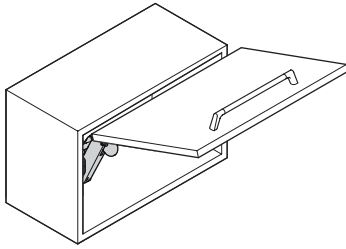

732.23.212

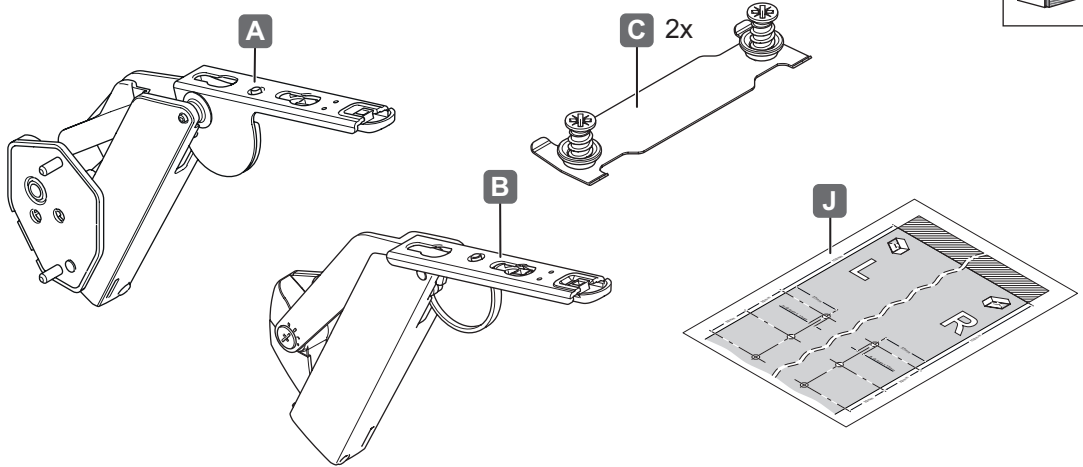
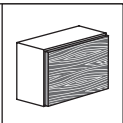

113793

+

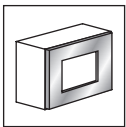

372.27.606

D 4x



E 4x



F 2x

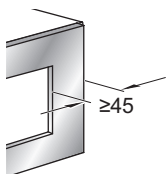
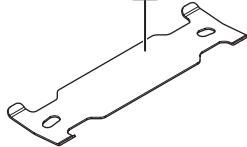

≥45

+

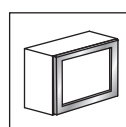

372.27.608

G

H

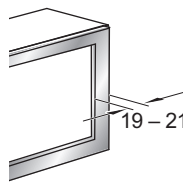
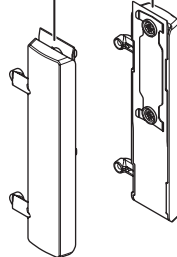

19-21



M4x10

K 4x



HDE 20.06.2024

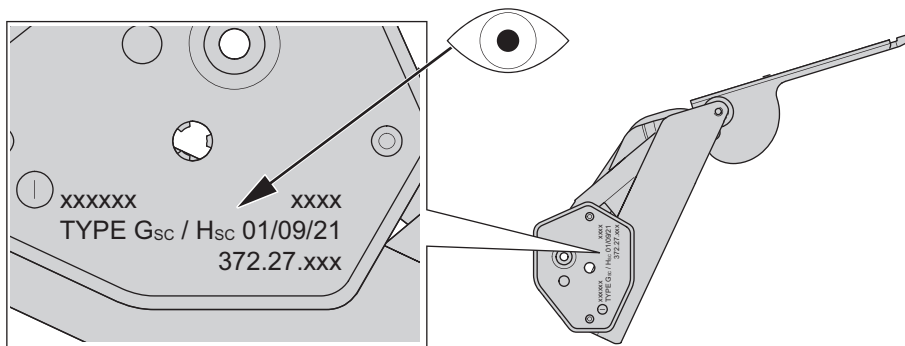

Free space 6.15 G	372.27.721	372.27.521	372.27.321	372.27.421
Free space 6.15 H	372.27.722	372.27.522	372.27.322	372.27.422

732.23.212

Y	X
16	117
18	110
19	107
22	96
24	90
26	83
28	76

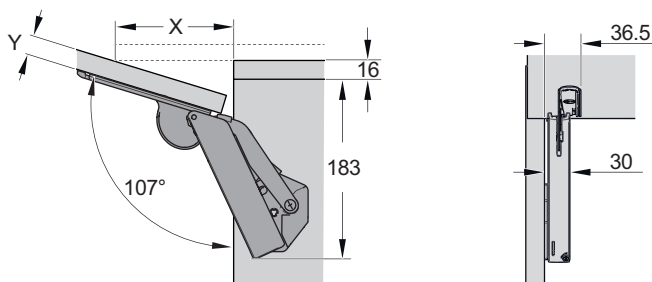

113793

Y	A _{max.} : 107°	A _{max.} : 90°
16	22	33
18	21,5	
19	21	
22	20,5	
24	20	
26	19	
28	18,5	

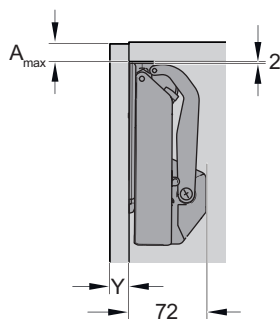

HDE 20.06.2024

i

mm

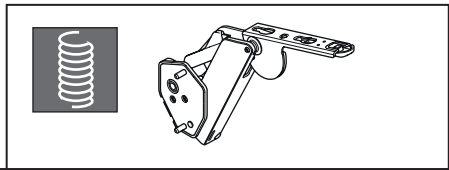
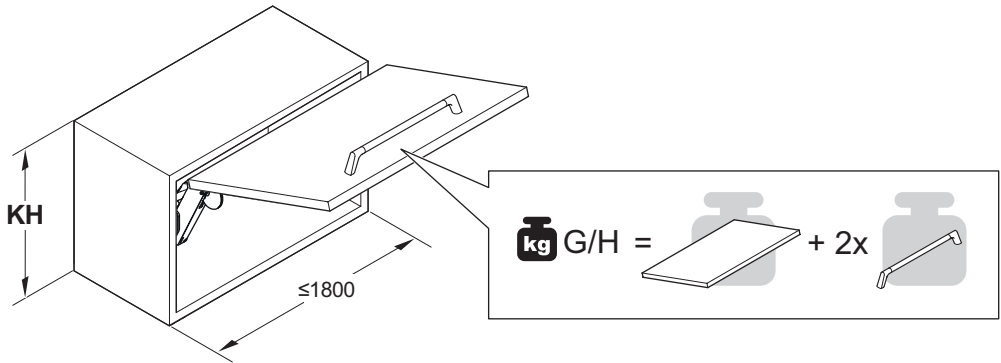

PF^* $= KH \times \text{kg}$ * Power Factor	G	H
	PF \approx 4080 - 6600	PF \approx 6300 - 9000
KH	kg G	kg H
350	11,7 – 18,9	18,0 – 25,7
375	10,9 – 17,6	16,8 – 24,0
400	10,2 – 16,5	15,8 – 22,5
425	9,6 – 15,5	14,8 – 21,2
450	9,1 – 14,7	14,0 – 20,0
475	8,6 – 13,9	13,3 – 18,9
500	8,2 – 13,2	12,6 – 18,0
525	7,8 – 12,6	12,0 – 17,1
550	7,4 – 12,0	11,5 – 16,4
575	7,1 – 11,5	11,0 – 15,7
600	6,8 – 11,0	10,5 – 15,0
625	6,5 – 10,6	10,1 – 14,4
650	6,3 – 10,2	9,7 – 13,8

732.23.212

113793

HDE 20.06.2024

1a

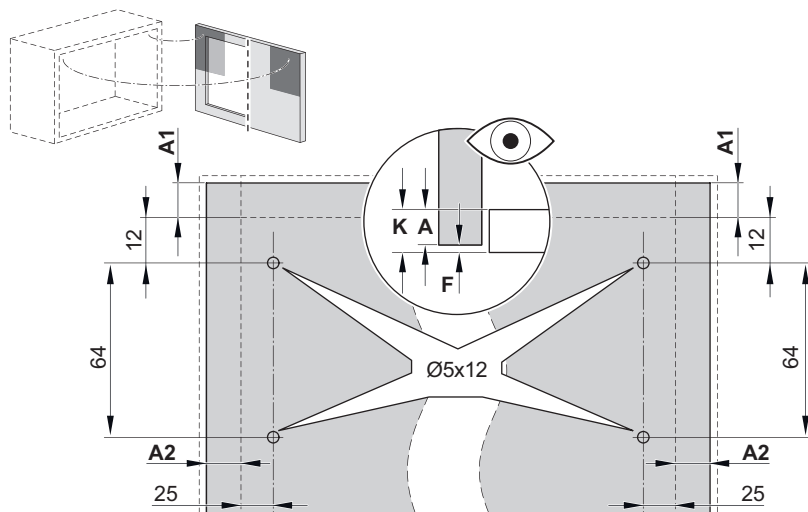
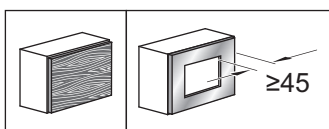
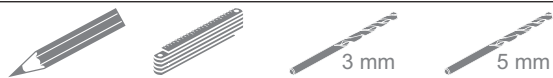

732.23.212

2A

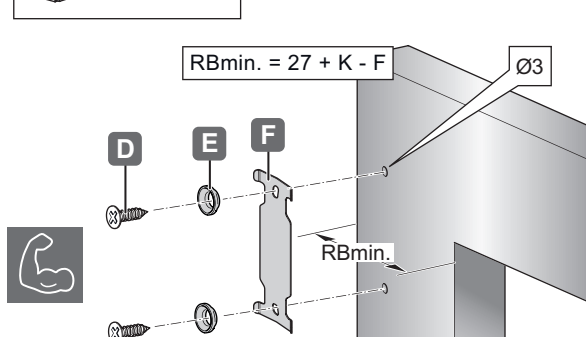
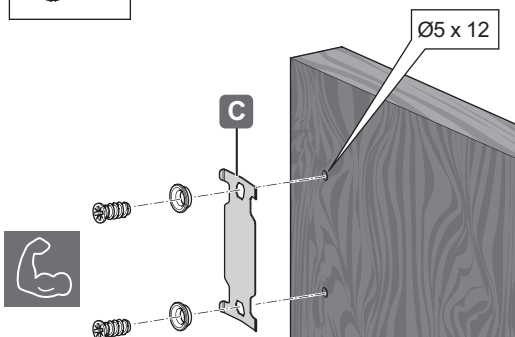
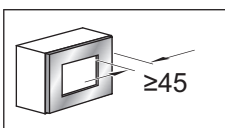
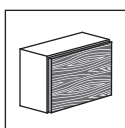

113793

i

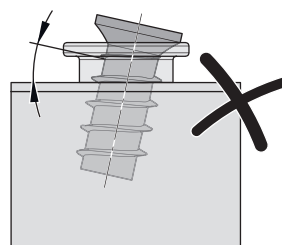
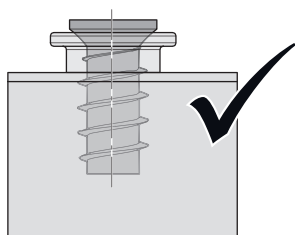

HDE 20.06.2024

1b

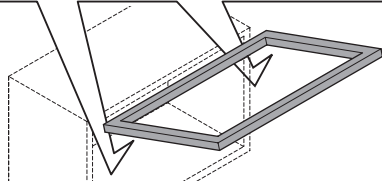
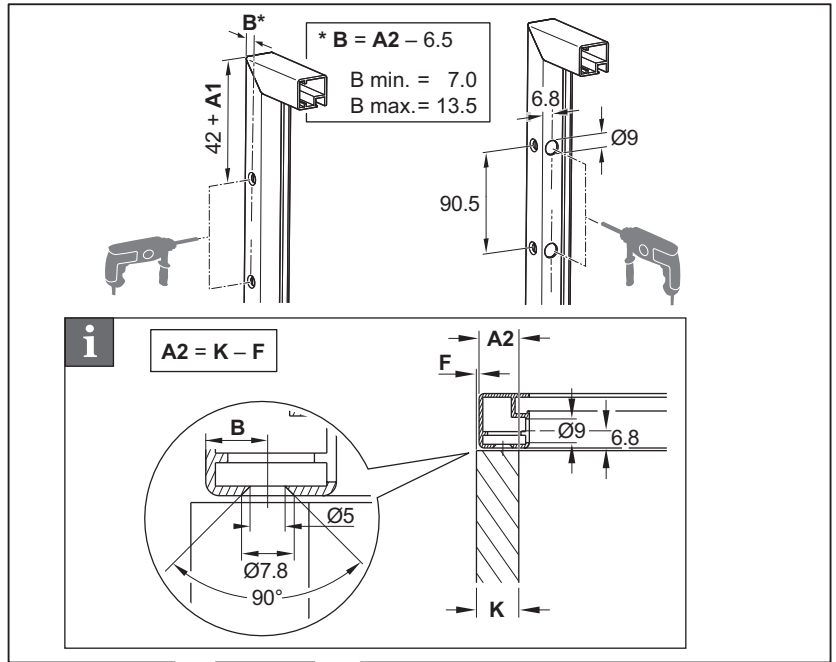
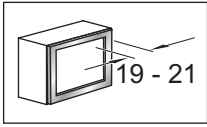
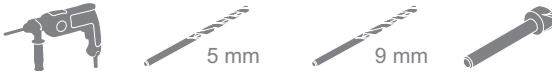

732.23.212

2B

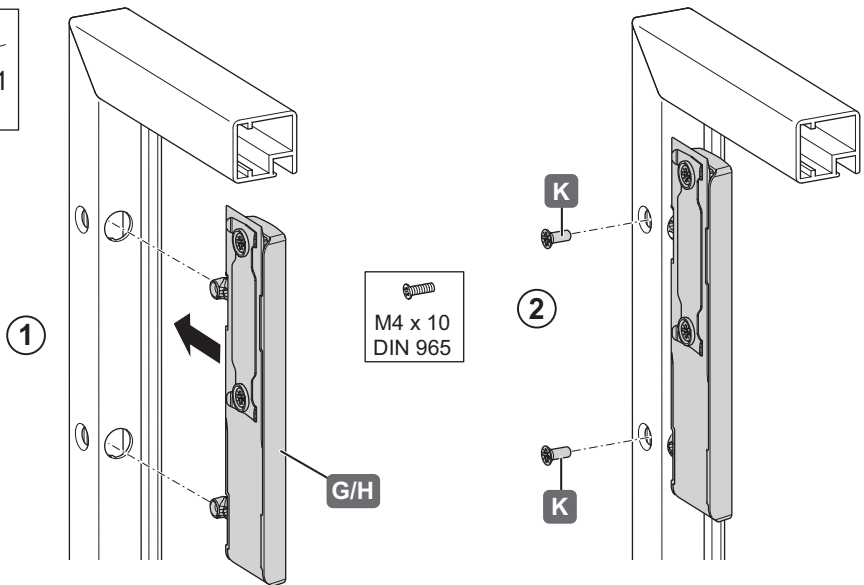
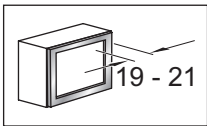

113793

HDE 20.06.2024

3



i

J

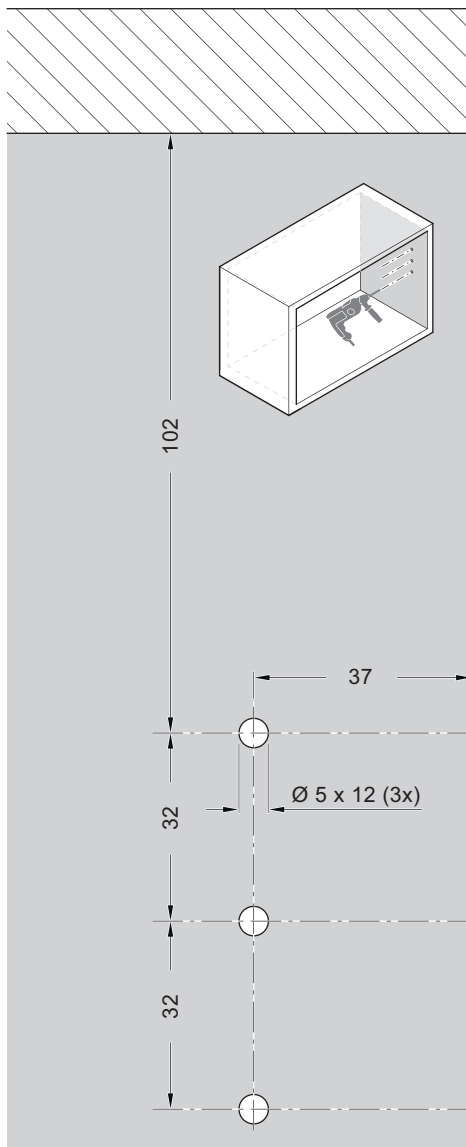
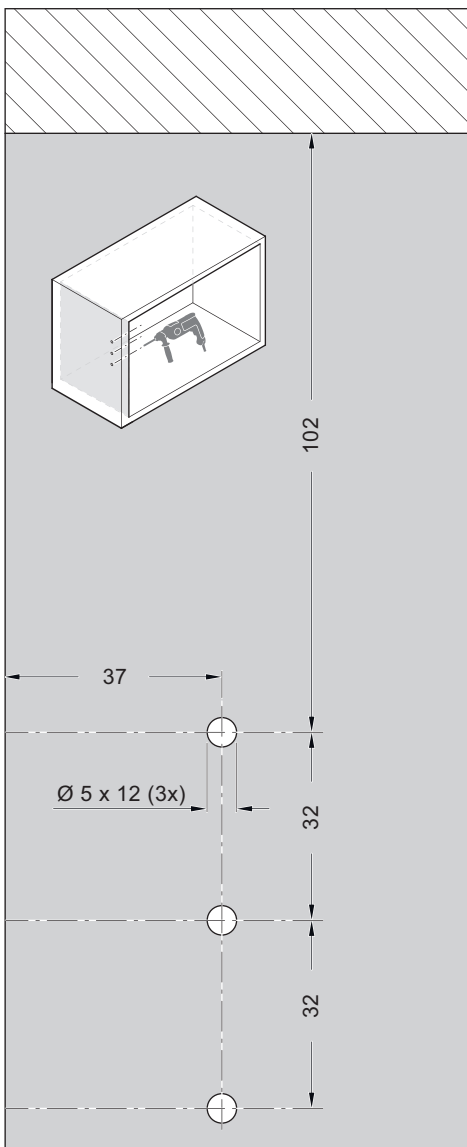

732.23.212

113793

HDE 20.06.2024

4

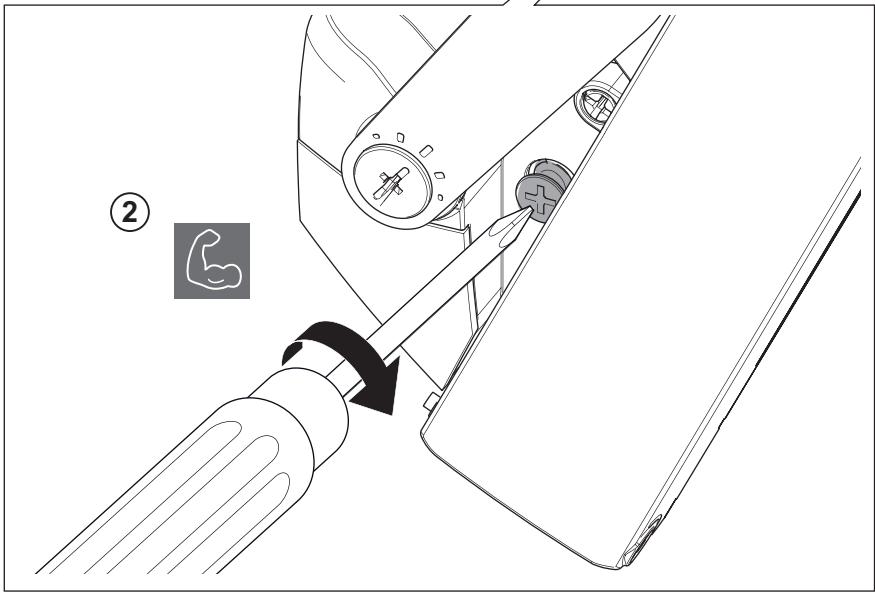
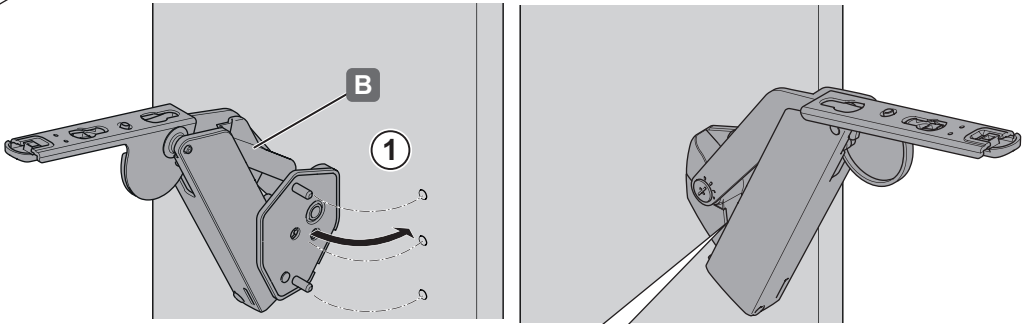
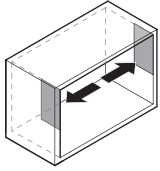

732.23.212

i

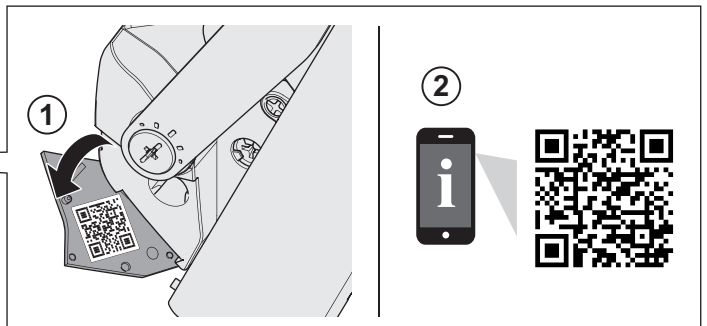
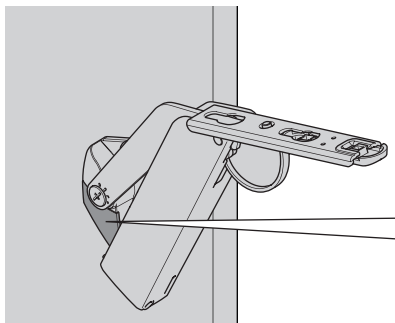

HDE 20.06.2024

5

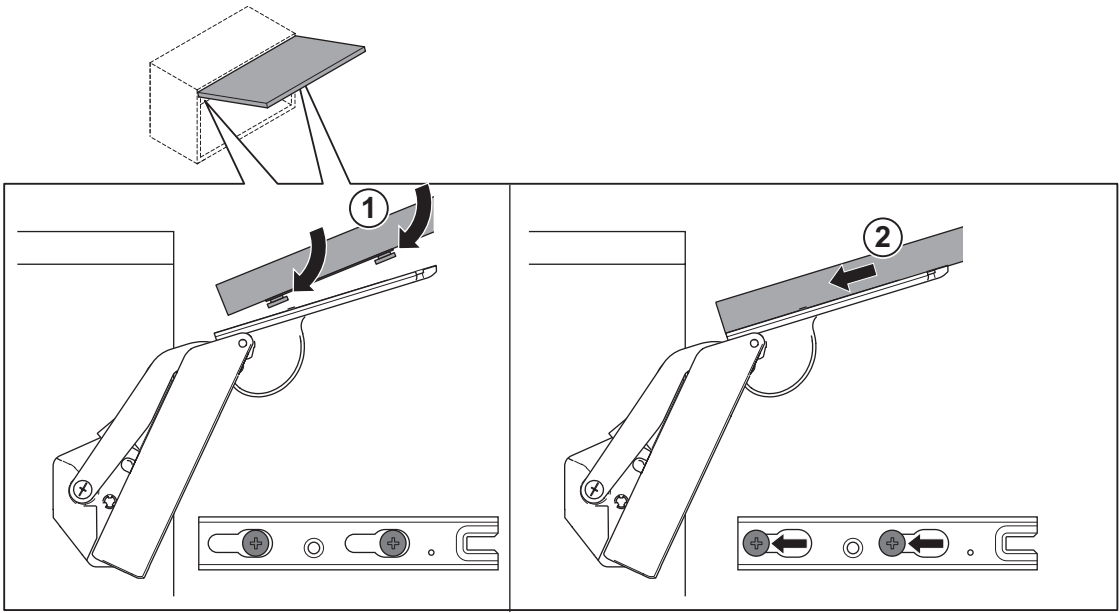

i

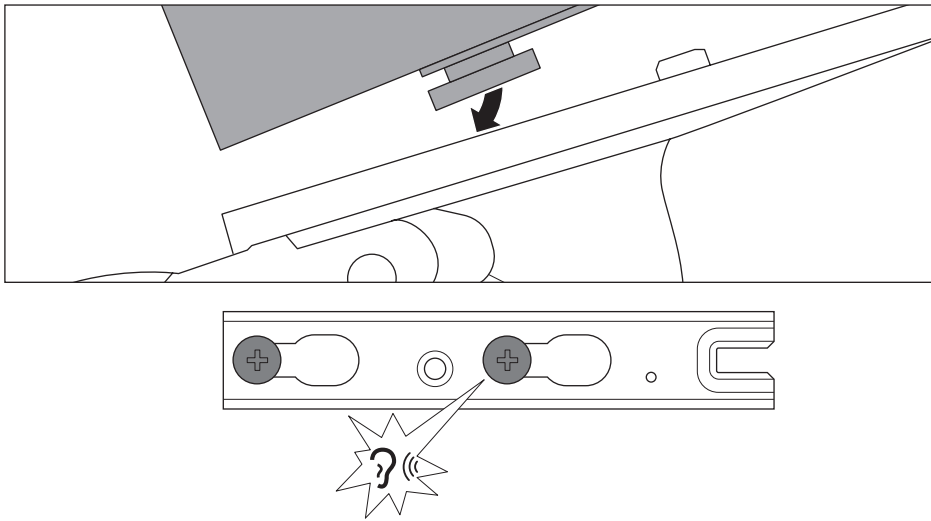

732.23.212

113793

HDE 20.06.2024

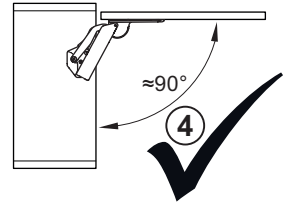
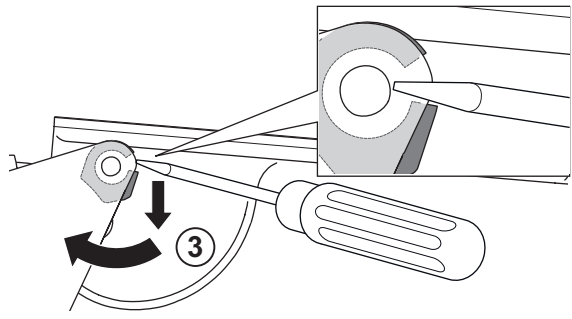
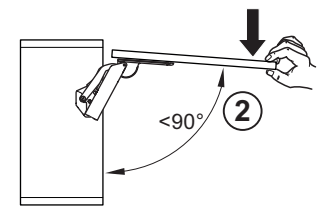
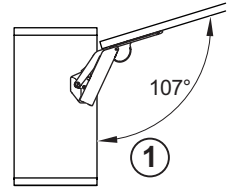
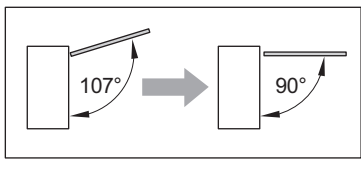

732.23.212

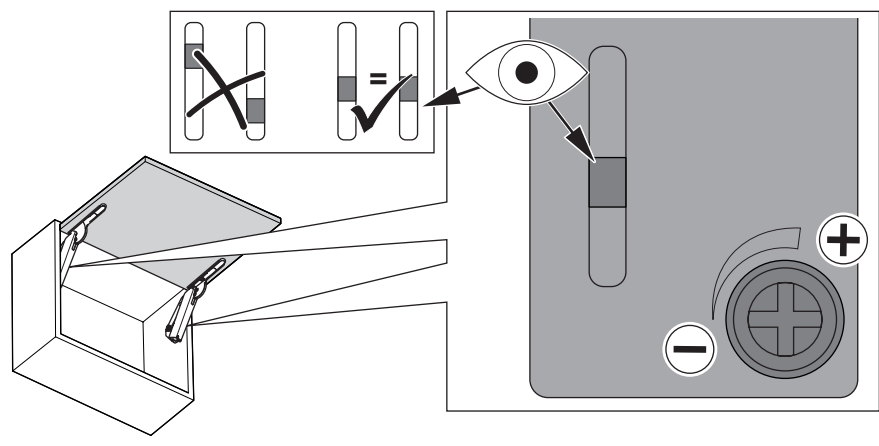
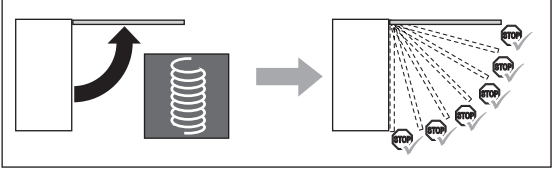

113793

HDE 20.06.2024

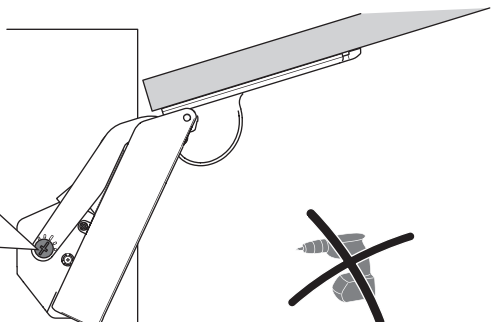
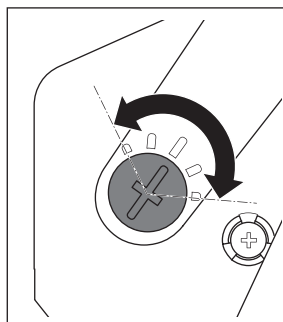
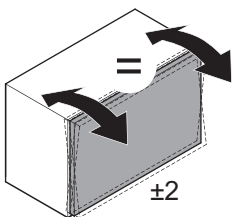
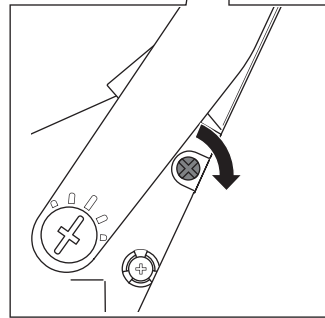
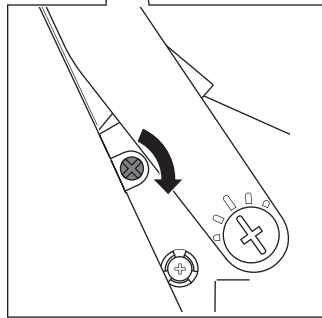
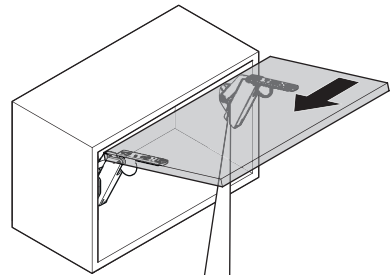
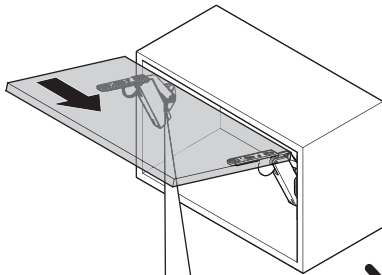
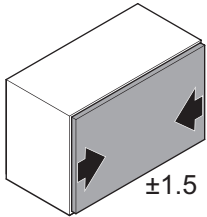
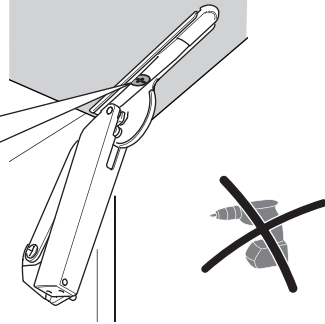
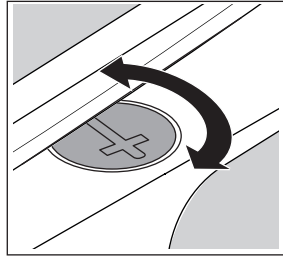
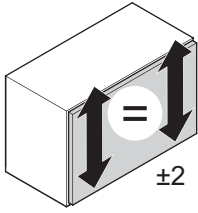

732.23.212

113793

HDE 20.06.2024

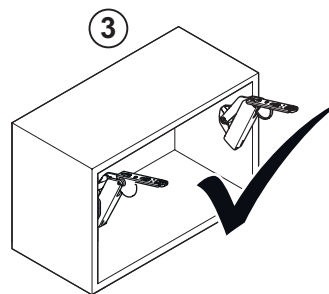
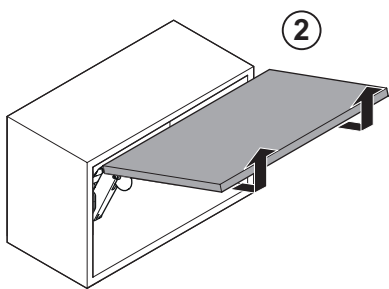
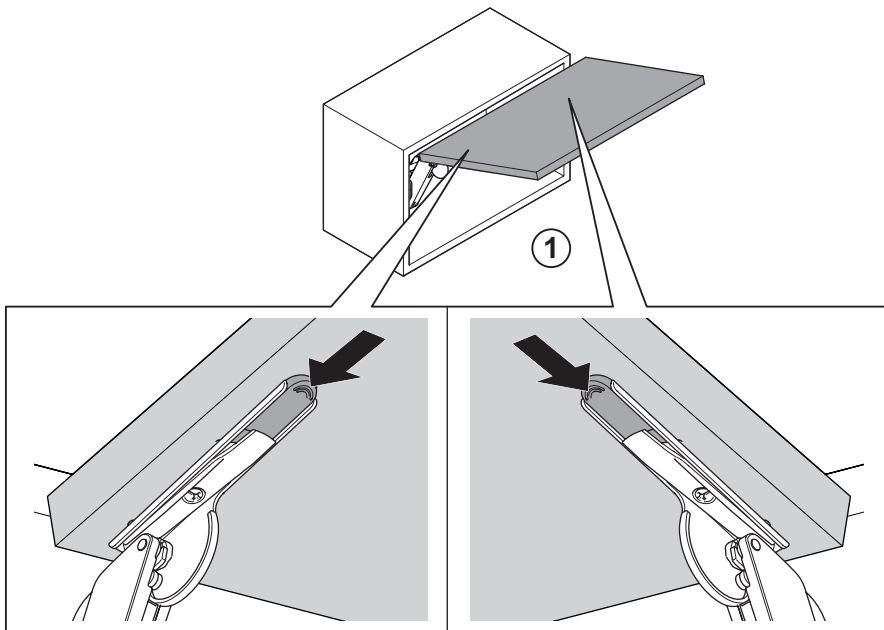

732.23.212

113793

HDE 20.06.2024

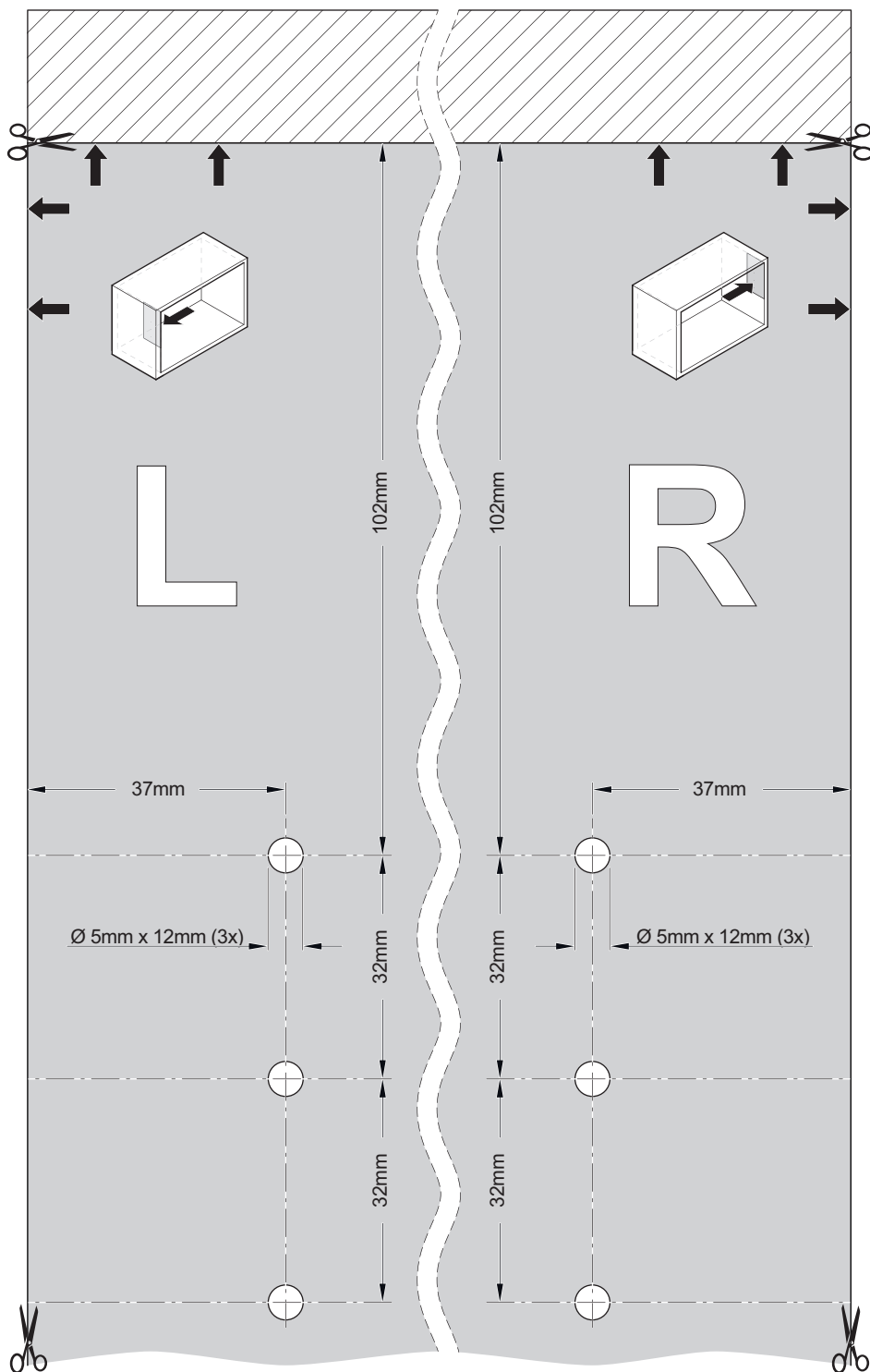
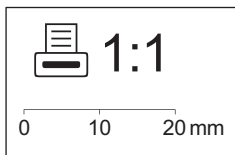

732.23.212

113793

HDE 20.06.2024