

TIOMOS Anreißlehre

Marking gauge / Règle de marquage / Dima per tracciare / Plantilla para marcar

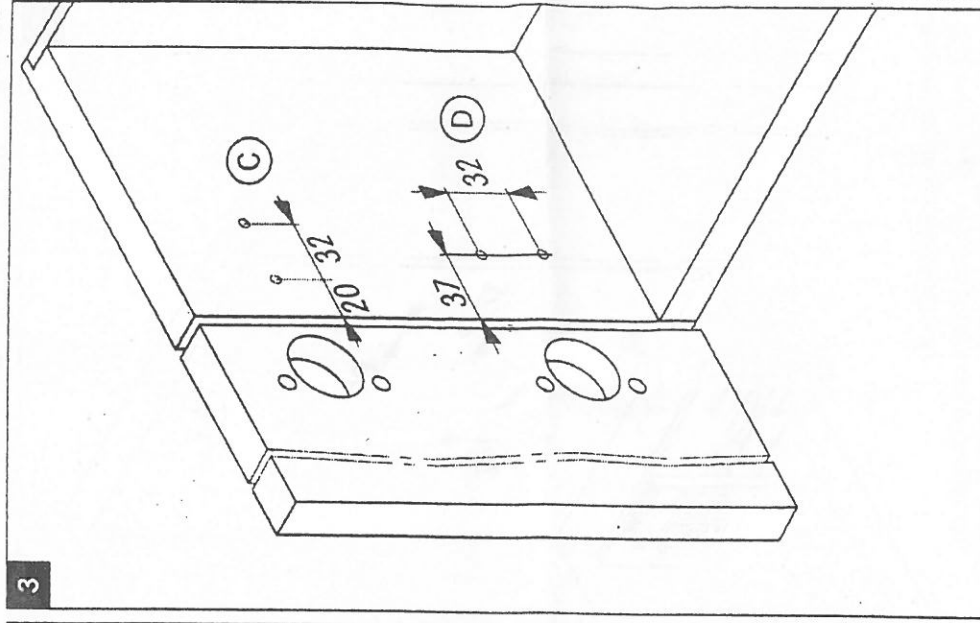
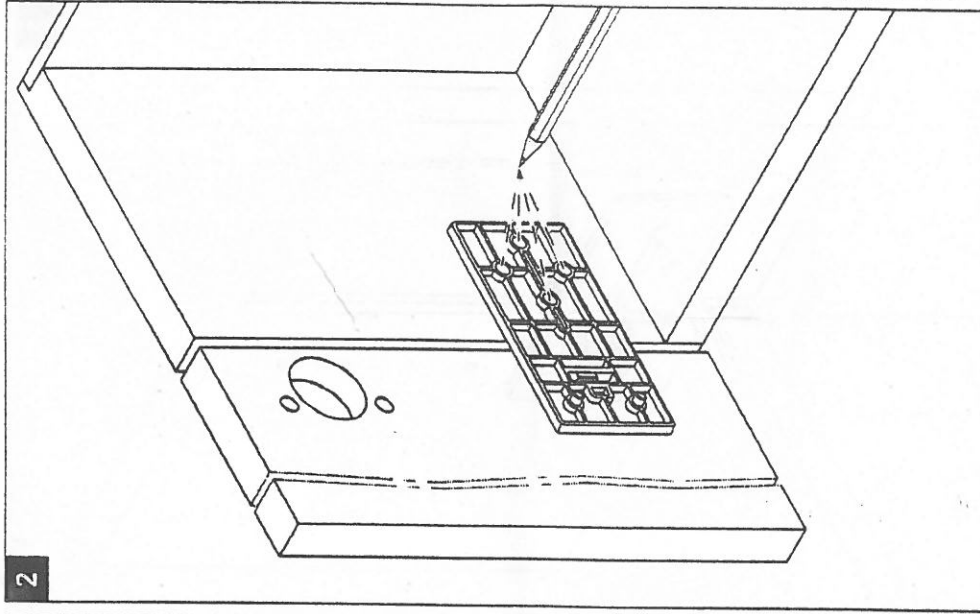
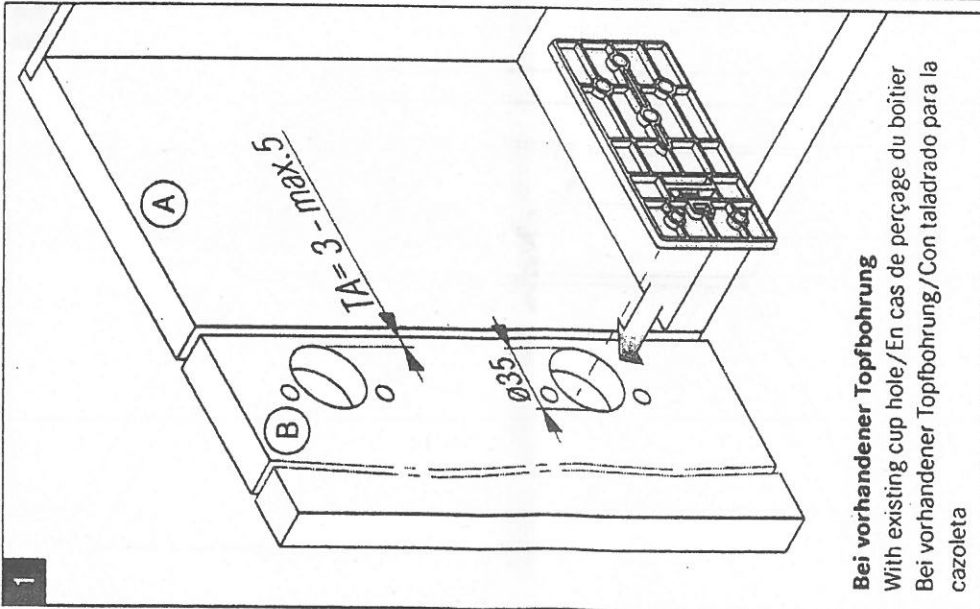

F07213588A000 - 09/2014

A Korpussseite / Cabinet side / Côté de caisson / Lato del mobile / Lateral del módulo

B Tür / Door / Porte / Anta / Puerta

C Linearmontageplatte / Linear mounting plate / Embase longitudinale / Piastrina di montaggio lineare / Base lineal

D Kreuzmontageplatte / Cross mounting plate / Embase en croix / Piastrina di montaggio a croce / Base en cruz

www.grass.eu, info@grass.eu



TIOMOS Anreißlehre

Marking gauge / Règle de marquage / Dima per tracciare / Plantilla para marcar

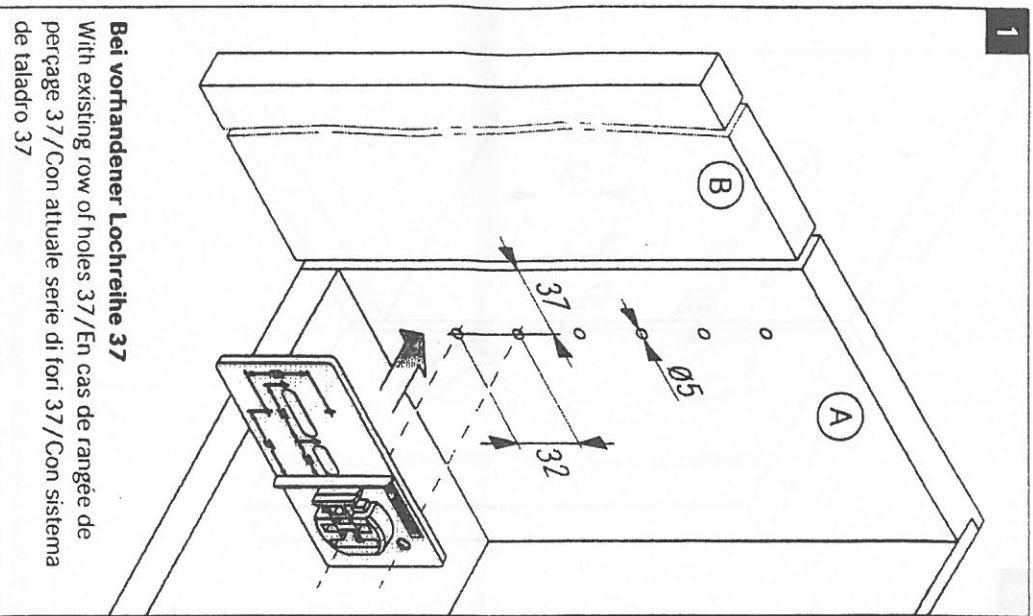

A Korpusseite / Cabinet side / Côté de caisson /
Lato del mobile / Lateral del módulo

www.grass.eu, info@grass.eu

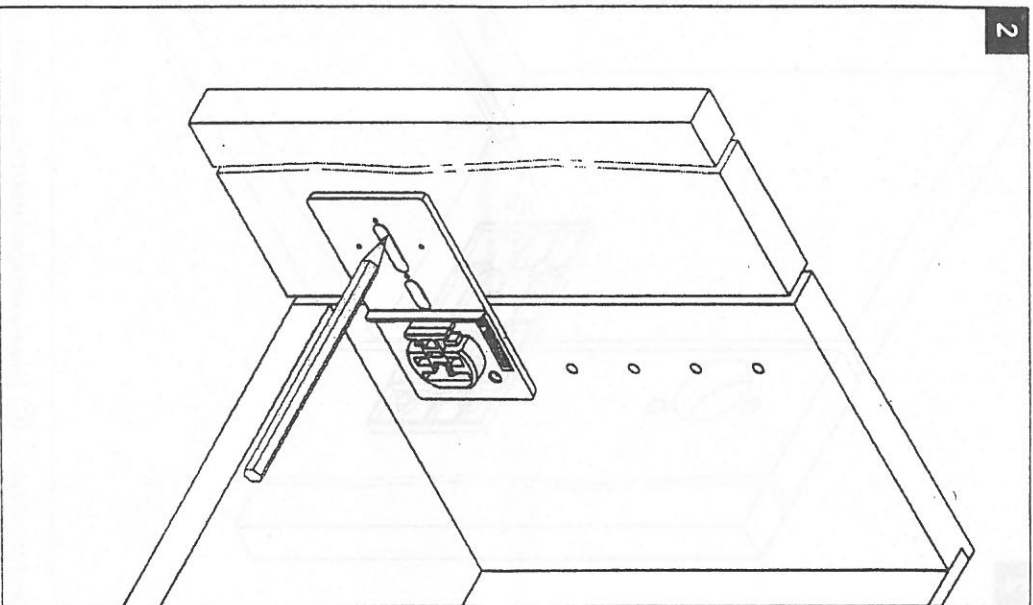

B Tür / Door / Porte / Anta / Tür

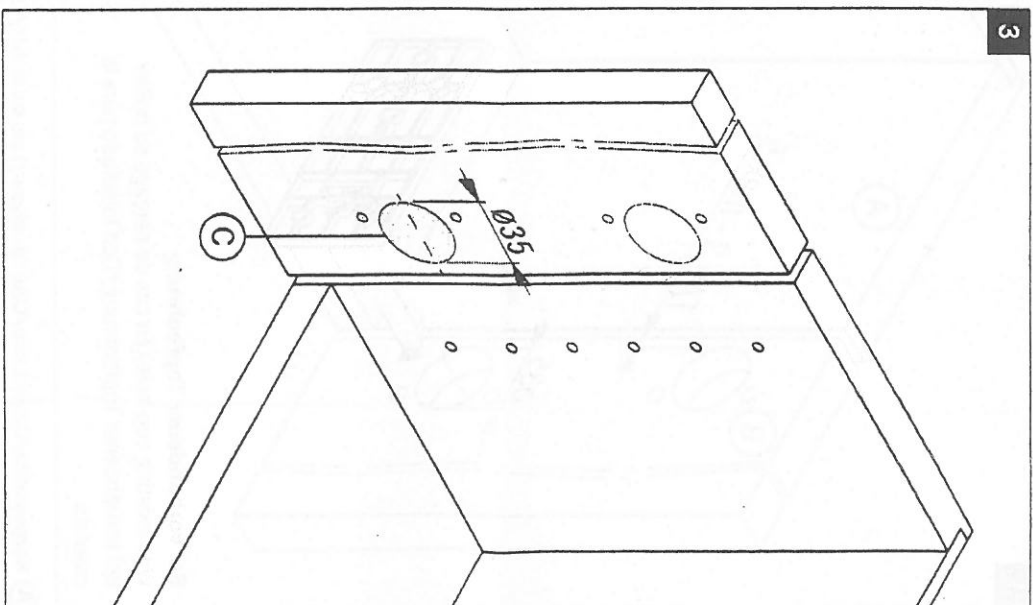

C Topfbohrung / Cup hole / Perçage du boîtier / Foro tazza / Taladrado para la cazoleta

G*GRASS®